

# ROTARY TWIN SCREW COMPRESSORS

HOWDEN COMPRESSORS



# WORLD PIONEERS OF ROTARY TWIN SCREW COMPRESSORS

**HOWDEN MANUFACTURES OIL INJECTED AND OIL FREE ROTARY TWIN SCREW COMPRESSORS, AND SUPPLIES BARE SHAFT OIL INJECTED SCREW COMPRESSORS FOR USE IN THE REFRIGERATION, GAS PROCESSING AND OTHER INDUSTRIES.**

Rotary twin screw compressor technology was developed in the 1930s by a Swedish company, SRM, in collaboration with Howden. We manufactured the world's first operational screw compressor and further developed the technology in the 1960s with the introduction of the oil injected twin screw compressor. This has revolutionised designs of refrigeration and gas handling plants worldwide.

Today, in thousands of installations worldwide, our oil injected screw compressors provide high integrity, low maintenance solutions for liquid chilling, direct refrigeration and gas compression applications.



## COMPRESSOR PACKAGE SYSTEMS

Howden Compressors is a specialist manufacturer of twin screw compressors. We supply oil injected bare shaft compressor units to independent packagers worldwide who design and supply gas and refrigeration systems on a local basis. For high specification process critical applications we can offer this packaging service by use of our own specialist knowledge and capabilities through our Howden global companies.

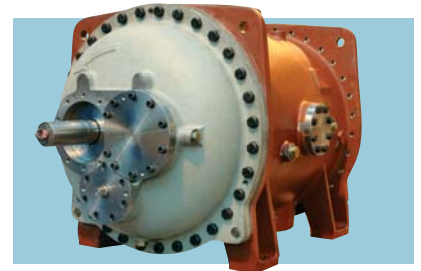

## RECENT DEVELOPMENTS

Our leadership in technology has been maintained over many years by total commitment to continuous product development. In particular, we are committed to ensuring that products meet current and future demands for environmental protection by using CFC free refrigerants and by containment of hazardous gases. Moreover our compressors have been developed to operate at high efficiencies to conserve energy and give low operating costs.



Our compressors are capable of operation on all known refrigerants and gases. We have over 30 years of experience on CO<sub>2</sub> compression, and as CO<sub>2</sub> becomes a standard refrigerant we have a proven compressor product available.

We are also actively increasing the range of our products to match customer requirements, such as high pressure gas boosters for aeroderivative gas turbines, which now typically require gas supply at pressures above 50 bar.





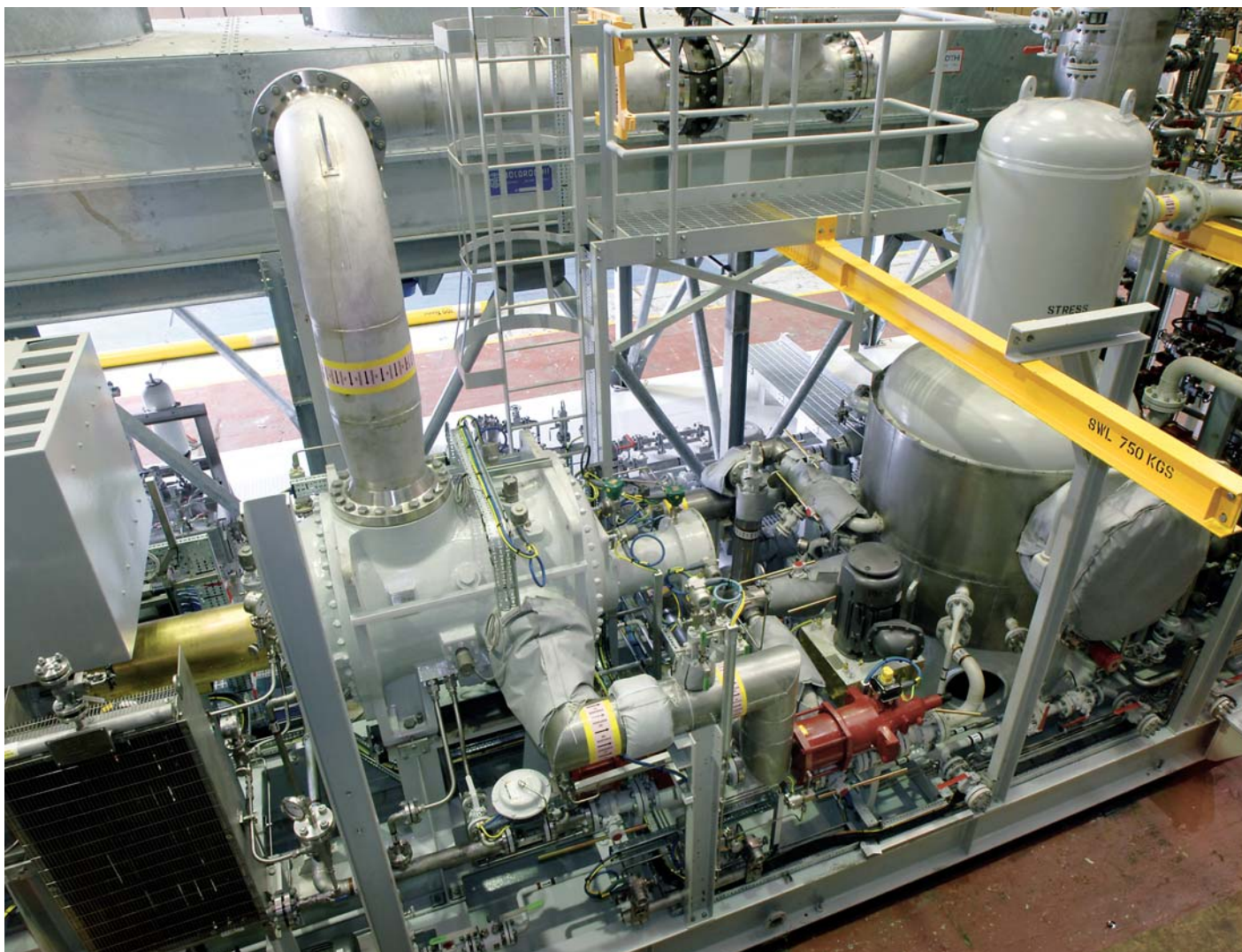

Screw compressor in Howden process gas package

## MANUFACTURING EXCELLENCE

We are committed to manufacturing the highest quality compressors in the industry. We employ state of the art machine tools to attain the highest possible accuracy and tolerances so as to produce compressors with high efficiency and outstanding reliability.

### ROTORS

All rotors for Howden twin screw compressors are machined from solid bar or forgings on highly accurate cutting machinery. The standard material is carbon steel, but forgings or special alloys can be used for more arduous applications. Following machining and balancing to ISO standards, male and female rotors are paired for assembly to ensure the ideal combination for maximum efficiency.

### CASINGS

Casings are precision machined from castings using state of the art horizontal machining centres to achieve the essential close tolerances. Cast iron is the normally casing material; alternative casing materials are spheroidal graphite iron or various grades of steel.

The main casing and the inlet and outlet end covers are flanged, bolted and dowelled through flanges to ensure correct alignment. Removal of the end covers provides ready access for maintenance when required.

### COMPRESSOR ASSEMBLY AND TESTING

All oil injected twin screw compressors are factory assembled by skilled engineers. The casing components are hydraulically tested to a minimum of 1.5 times maximum operating pressure to ensure integrity. Additionally, all oil injected compressors are tested with air under water following final assembly. The compressors are then mechanically run on air test rigs to confirm that volumetric efficiency, absorbed power, oil flows and vibration levels meet the stringent acceptance standards.

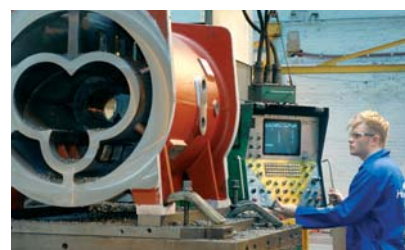



# BEST PRACTICES LIFETIME QUALITY AND CARE



## QUALITY CONTROL

We recognise the importance of a controlled manufacturing environment and Howden companies are accredited to ISO 9001:2000. Ongoing internal and external audits of quality control systems are applied to ensure continued compliance with necessary control procedures. For particular applications quality plans are prepared to meet specific customer requirements.

Today in thousands of applications worldwide, Howden screw compressors provide high integrity, low maintenance solutions for liquid chilling, direct refrigeration and gas compression.

## DESIGN SPECIFICATIONS

Our twin screw compressors are designed to match the exacting specifications required by our customers. They comply with International standards and codes, e.g., API 619. Compressors are generally Lloyds approved, and installations have been accepted by many major authorities such as Lloyds, Bureau Veritas, Norske Veritas, RINA, DSRK, Bureau de Mines, ABS, Germanischer Lloyd and NKK.

## TESTING

Howden has extensive test facilities. Comprehensive testing ensures that the test performance data, particularly relating to the computer selection programs for standard gases and refrigerants, are as accurate as possible. Project specific tests, such as to API 619, can be carried out to customer requirements. Our thorough testing gives confidence that the unit will perform reliably throughout its life.

## AFTERSALES

We provide a lifelong spare parts and maintenance service through our global network. Spare parts are authenticated with our "Original Spare Parts" certificate and it is recommended that only these parts are used. Parts are generally supplied in pre-packaged kits that provide all items for particular types of model and maintenance operation.



COMPREHENSIVE  
TESTING ENSURES  
THAT THE TEST  
PERFORMANCE DATA  
ARE AS ACCURATE  
AS POSSIBLE.

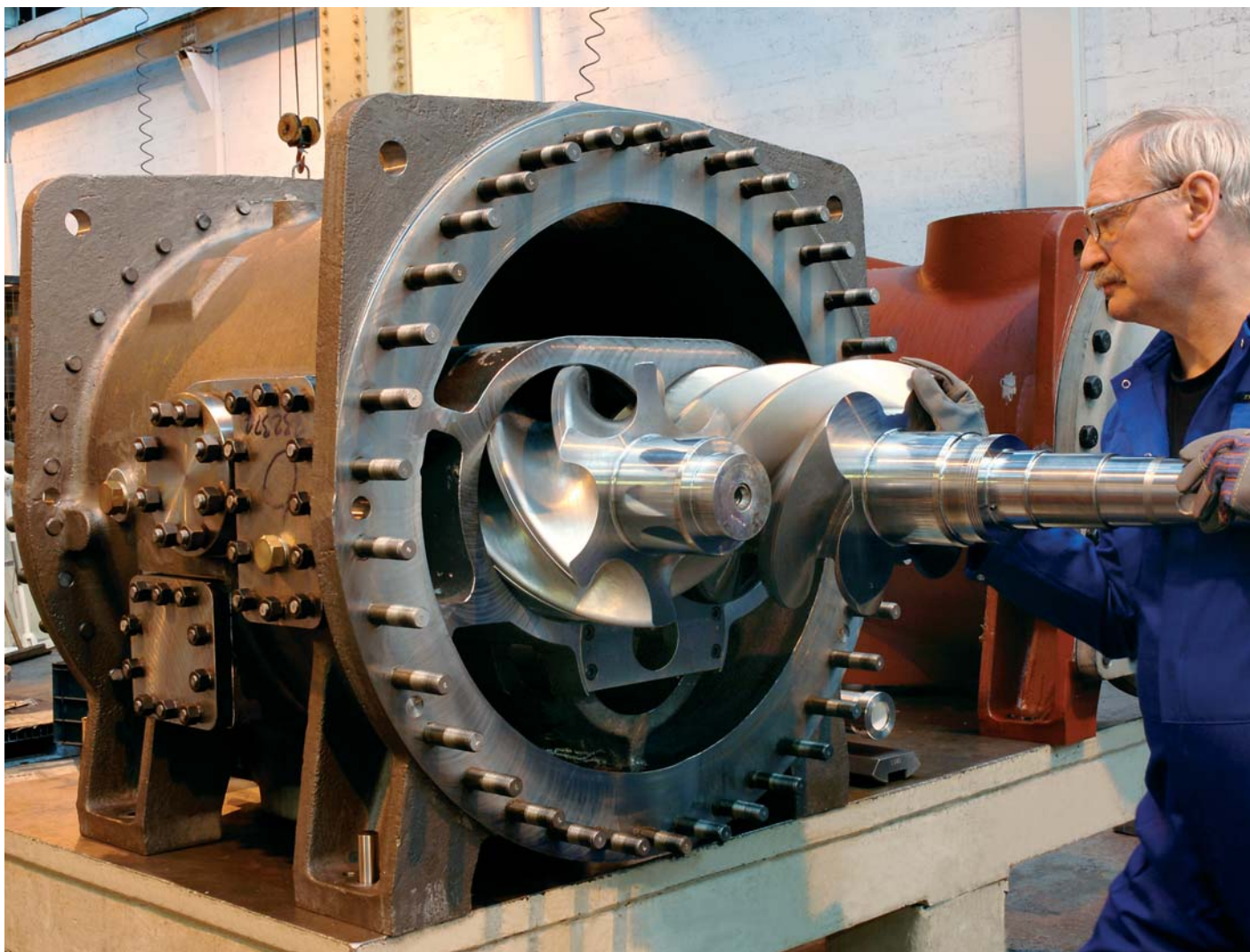

## TWIN SCREW COMPRESSORS PRINCIPLES OF OPERATION

### DESIGN CONCEPT

Compression is achieved by the intermeshing of two helical rotors contained in a suitable casing. Figures 1–4 give details of the compression cycle.

The Howden twin screw compressor is a positive displacement rotary design. As such it has the characteristics and stability of reciprocating compressors but in addition offers particular advantages:

- Reduced physical size.
- Fewer moving parts.
- Low vibration.
- Extended operating life cycle.

### OPTIONS

Our compressors have a range of design options. Typical ones are:

- Twin wall construction with sleeve bearings.
- Single wall construction with roller bearings.
- Slide valve capacity control from 100% to 10% nominal.
- Inverter speed control.
- Variable volume ratio.
- Superfeed.

- Oil cooling.
- Liquid refrigeration injection.
- Specialist sealing systems.

### FEATURES AND BENEFITS

#### Positive displacement

- Cannot surge. High compression ratios per stage.

#### Rotary action

- Vibration free running.
- Extreme reliability & on-line availability.
- Smooth gas flow, low pulsation.
- Lightweight foundations.

#### Stiff action rotors

- Ability to withstand high pressure differences.

#### No inlet or outlet valves

- Lower maintenance costs.

#### Compact size & light weight

- Minimal space and foundation requirement, resulting in low installation costs.

#### Designed for long periods of continuous running

- Maximum on-line availability.
- Minimal service requirements.



**Fig 1**  
Gas is drawn in to fill the interlobe space between adjacent lobes.



**Fig 2**  
As the rotors mesh, the gas is trapped between the rotors and the casing.



**Fig 3**  
Continued rotation progressively reduces the space occupied by the gas, causing compression.

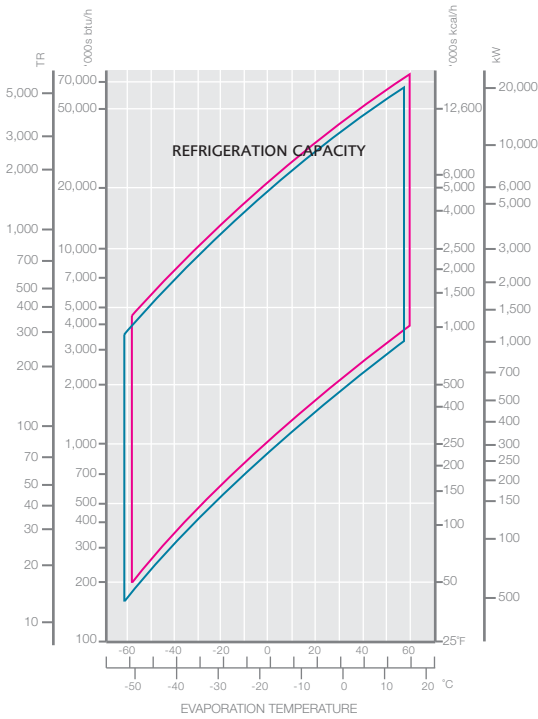

**Fig 4**  
Compression continues until the interlobe space becomes exposed to the outlet port, through which the gas is discharged.



# WRV TECHNICAL DATA: TYPICAL PERFORMANCE

## WRV AMMONIA



## TYPICAL EFFECT OF SUPERFEED

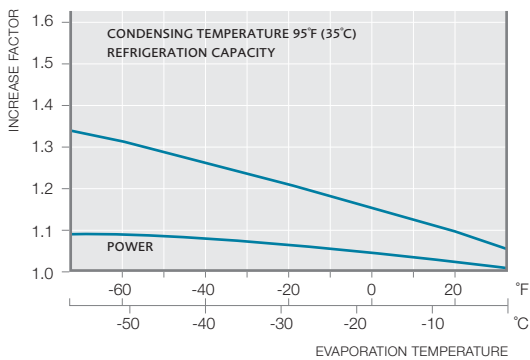

## TYPICAL PERFORMANCE

### GAS HANDLING

Typical gases or refrigerants handled by the Howden range of oil injected screw compressors include:

#### Refrigerants

- R717
- R134a
- R404A
- R407C
- R410A
- R502
- R507

#### Gases

- Ammonia
- Butane
- Carbon Dioxide
- Fuel gas
- Helium
- Hydrocarbon
- Ammonia (Wet & Mixed)
- Hydrogen
- Methane
- Natural Gas
- Nitrogen
- Propane
- Propylene
- Town Gas

NB. In some cases, for example in refineries, hydrocarbon gases will be used as refrigerants.

## SUPERFEED CYCLE

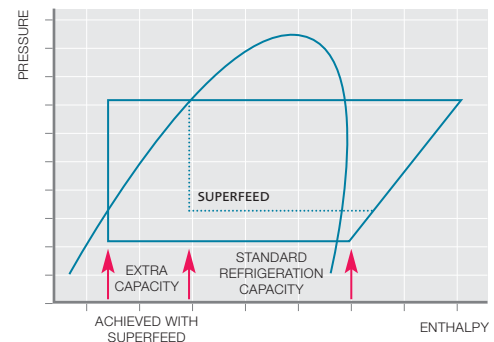

## SUPERFEED

The Howden superfeed system is a development of the oil injected screw compressor design. All oil injected compressors are equipped with an additional gas port, located along the length of the compression chamber. Feeding refrigerant to this port from a superfeed/economiser vessel within the refrigeration system offers increased evaporator capacity of up to 20 percent, with virtually no increase in absorbed power.

## KEY TO GRAPHS

- Full duty 50 Hz (excluding Superfeed)  
Condensing temperature 35°C (95°F)
- Full duty 60 Hz (excluding Superfeed)  
Condensing temperature 35°C (95°F)

## NOTES

Refrigeration capacity based on 5.6°C (10°F) superheat at compressor suction and no sub-cooling of condensed liquid.  
No allowance has been made for pressure losses between the evaporator and the compressor suction flange.



# WRV TECHNICAL DATA

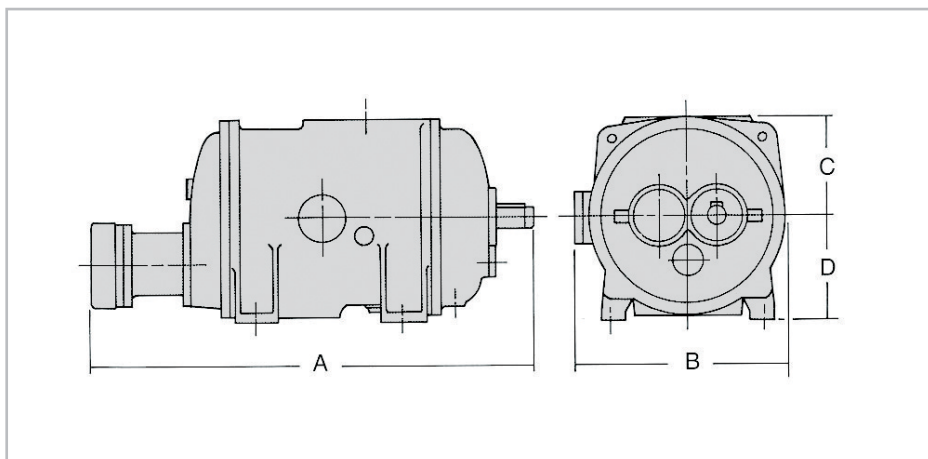

The WRV range has 6 frame sizes each with between 2 and 6 L/D ratios (all with clockwise rotation).



VOC Emission Control



Gas Turbine Installation



Helium Refrigeration

HOWDEN COMPRESSOR SPECIFICATION	*SWEEP VOLUME 50Hz		*SWEEP VOLUME 60Hz		SUCTION PORT Ø		DISCHARGE PORT Ø		DIMENSION A			DIMENSION B			DIMENSION C			DIMENSION D			WEIGHT APPROX.	
	m <sup>3</sup> /hr	cfm	m <sup>3</sup> /hr	cfm	mm	in	mm	in	mm	ft	in	mm	ft	in	mm	ft	in	mm	ft	in	Kg	lb
WRV 163/1.45	550	325	660	390	125	5	75	3	1063	3	5 7/8	490	1	7 1/4	248	0	9 3/4	250	0	9 7/8	470	1036
WRV 163/1.80	680	400	820	480	125	5	75	3	1120	3	8 1/4	490	1	7 1/4	248	0	9 3/4	250	0	9 7/8	495	1091
WRV 204/1.10	815	480	975	575	150	6	100	4	1201	3	11 1/4	640	2	1 1/8	310	0	12 1/4	315	0	12 3/8	760	1675
WRV 204/1.45	1095	645	1315	775	200	8	125	5	1273	4	2 1/8	640	2	1 1/8	310	0	12 1/4	315	0	12 3/8	850	1874
WRV 204/1.65	1220	720	1465	860	200	8	125	5	1314	4	3 3/4	640	2	1 1/8	310	0	12 1/4	315	0	12 3/8	887	1955
WRV 204/1.93	1340	790	1610	950	200	8	125	5	1370	4	6	640	2	1 1/8	310	0	12 1/4	315	0	12 3/8	925	2039
WRVi 255/1.10	1590	935	1905	1120	200	8	150	6	1493	4	10 3/4	692	2	3 1/4	349	1	1 3/4	362	1	2 1/8	1200	2645
WRVi 255/1.30	1755	1035	2105	1240	200	8	150	6	1544	5	0 3/4	692	2	3 1/4	349	1	1 3/4	362	1	2 1/4	1270	2799
WRVi 255/1.45	2150	1270	2580	1520	255	10	200	8	1583	5	2 1/4	692	2	3 1/4	349	1	1 3/4	362	1	2 1/4	1325	2921
WRVi 255/1.65	2395	1410	2870	1690	255	10	200	8	1633	5	4 1/4	692	2	3 1/4	349	1	1 3/4	362	1	2 1/4	1422	3134
WRVi 255/1.93	2630	1550	3155	1855	255	10	200	8	1705	5	7	692	2	3 1/4	349	1	1 3/4	362	1	2 1/4	1540	3395
WRV 255/2.20	3190	1880	3830	2255	255	10	200	8	1815	5	11 1/2	692	2	3 1/4	349	1	1 3/4	362	1	2 1/4	1650	3638
WRVi 321/1.32	3830	2255	4595	2705	255	10	200	8	2005	6	7	940	3	1	471	1	6 1/2	500	1	7 5/8	2925	6447
WRVi 321/1.65	4790	2820	5745	3380	300	12	255	10	2110	6	11	940	3	1	471	1	6 1/2	500	1	7 5/8	3150	6943
WRVi 321/1.93	5260	3095	6310	3715	300	12	255	10	2200	7	2 1/2	940	3	1	471	1	6 1/2	500	1	7 5/8	3260	7186
WRV 321/2.20	6385	3760	7660	4510	350	14	300	12	2345	7	8 3/8	940	3	1	471	1	6 1/2	500	1	7 5/8	3500	7715
WRVi 365/165	6771	3985	8012	4716	350	14	300	12	2418	7	11 1/4	1125	3	8 1/2	565	1	10 1/4	590	1	11 1/4	5500	12125
WRVi 365/193	7920	4662	9372	5516	350	14	300	12	2520	8	3 1/4	1125	3	8 1/2	565	1	10 1/4	590	1	11 1/4	6100	13450
WRV 510/1.32	7660	4510	9190	5410	350	14	255	10	2920	9	7	1560	5	1 1/8	750	2	5 1/2	750	2	5 1/2	10800	23806
WRV 510/1.65	9575	5640	11490	6760	400	16	300	12	3090	10	1 1/8	1560	5	1 1/8	750	2	5 1/2	750	2	5 1/2	11500	25349
WRV 510/1.93	10510	6190	12615	7425	400	16	300	12	3233	10	7 1/4	1560	5	1 1/8	750	2	5 1/2	750	2	5 1/2	11800	26010

The company operates a policy of continuous product development and reserves the right to alter the data provided without notice.

\*Swept volume at 3000 rpm except WRV510 range which is measured at 1500rpm \*\*Swept volume at 3600 rpm except WRV510 which is measured at 1800 rpm.

# XRV TECHNICAL DATA: TYPICAL PERFORMANCE

## XRV AMMONIA

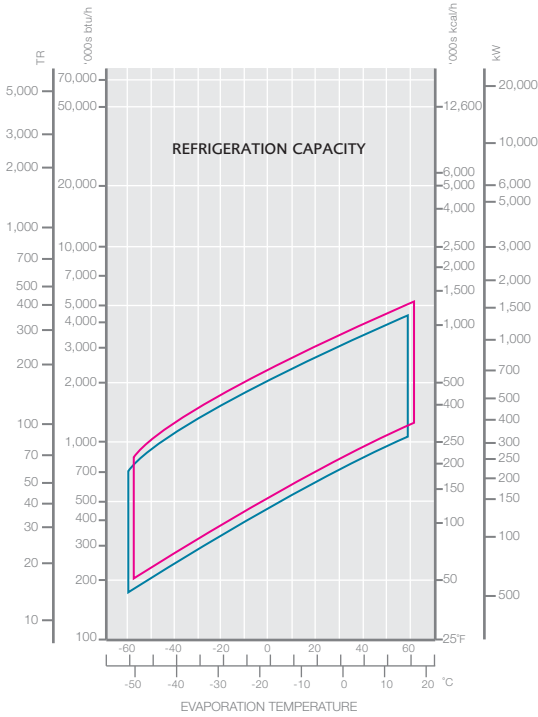

## XRV R404A

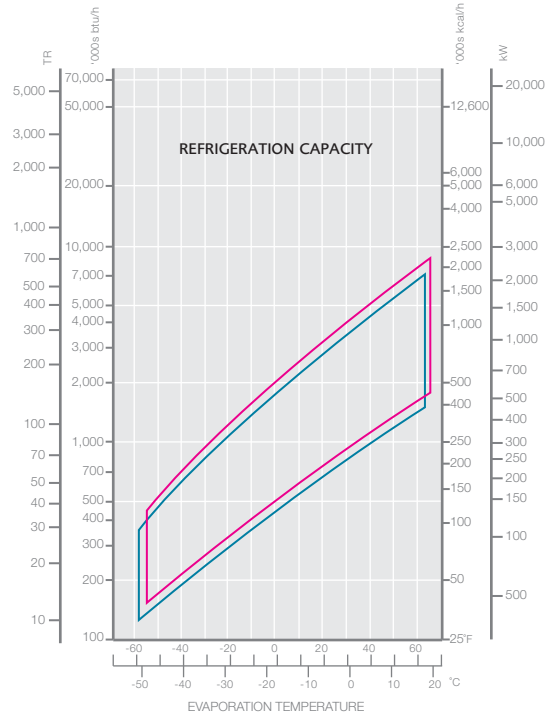

## XRV SUPERFEED EFFECT AMMONIA

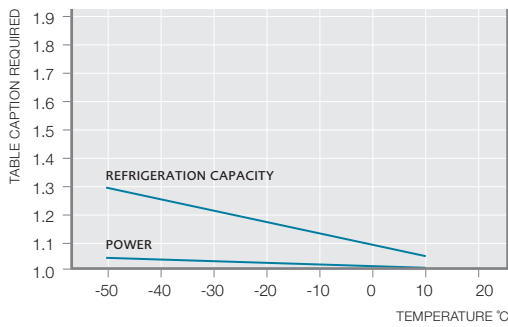

## XRV SUPERFEED EFFECT R404A

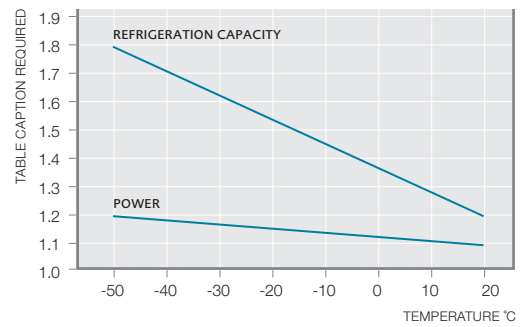

### KEY TO GRAPHS

- Full duty 50 Hz (excluding Superfeed)  
Condensing temperature 35°C (95°F)
- Full duty 60 Hz (excluding Superfeed)  
Condensing temperature 35°C (95°F)

### NOTES

Refrigeration capacity based on 5.6°C (10°F) superheat at compressor suction and no sub-cooling of condensed liquid.

No allowance has been made for pressure losses between the evaporator and the compressor suction flange.





# XRV COMPRESSORS



Marine Freezing Unit



Glycol Chiller



Ethyleneglycol Chiller Unit

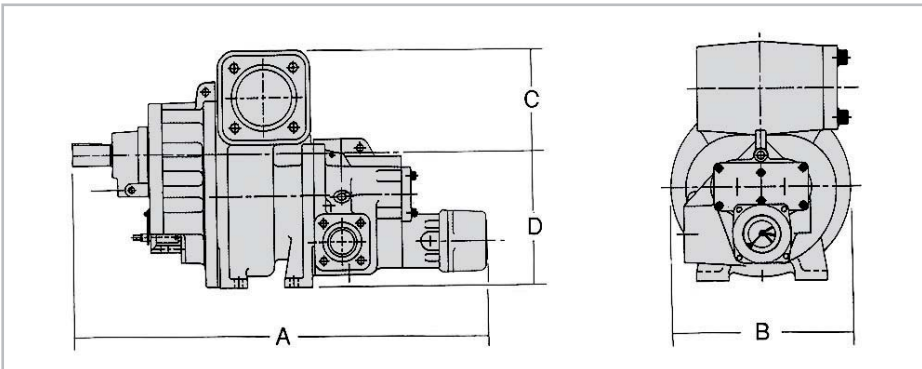

**XRV 127/1.65 Compressor**  
(with anti-clockwise rotation except for XRV 127-R1)

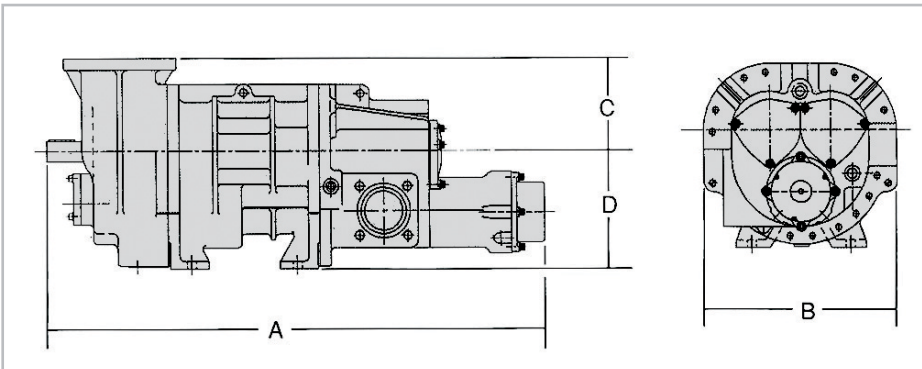

**XRV 163 & XRV 204 Compressors**  
(all with clockwise rotation)

HOWDEN COMPRESSOR SPECIFICATION	*SWEPT VOLUME 50Hz		*SWEPT VOLUME 60Hz		SUCTION PORT Ø		DISCHARGE PORT Ø		DIMENSION A		DIMENSION B		DIMENSION C		DIMENSION D		WEIGHT APPROX.	
	m <sup>3</sup> /hr	cfm	m <sup>3</sup> /hr	cfm	mm	in	mm	in	mm	ft in	mm	ft in	mm	ft in	mm	ft in	Kg	lb
XRV 127-R1	293	172	352	207	100	4	50	2	850	2 9 <sup>7</sup> / <sub>16</sub>	390	1 3 <sup>3</sup> / <sub>8</sub>	299	0 11 <sup>3</sup> / <sub>4</sub>	201	0 7 <sup>5</sup> / <sub>16</sub>	250	550
XRV 127-R3	397	234	476	280	100	4	50	2	900	2 11 <sup>7</sup> / <sub>16</sub>	390	1 3 <sup>3</sup> / <sub>8</sub>	209	0 8 <sup>1</sup> / <sub>4</sub>	291	0 11 <sup>1</sup> / <sub>2</sub>	250	550
XRV 127-R4	489	288	586	345	100	4	50	2	900	2 11 <sup>7</sup> / <sub>16</sub>	390	1 3 <sup>3</sup> / <sub>8</sub>	209	0 8 <sup>1</sup> / <sub>4</sub>	291	0 11 <sup>1</sup> / <sub>2</sub>	250	550
<b>XRV 127-R5</b>	<b>576</b>	<b>340</b>	-	-	<b>100</b>	<b>4</b>	<b>50</b>	<b>2</b>	<b>900</b>	<b>2 11<sup>7</sup>/<sub>16</sub></b>	<b>390</b>	<b>1 3<sup>3</sup>/<sub>8</sub></b>	<b>209</b>	<b>0 8<sup>1</sup>/<sub>4</sub></b>	<b>291</b>	<b>0 11<sup>1</sup>/<sub>2</sub></b>	<b>250</b>	<b>550</b>

HOWDEN COMPRESSOR SPECIFICATION	*SWEPT VOLUME 50Hz		*SWEPT VOLUME 60Hz		SUCTION PORT Ø		DISCHARGE PORT Ø		DIMENSION A		DIMENSION B		DIMENSION C		DIMENSION D		WEIGHT APPROX.	
	m <sup>3</sup> /hr	cfm	m <sup>3</sup> /hr	cfm	mm	in	mm	in	mm	ft in	mm	ft in	mm	ft in	mm	ft in	Kg	lb
XRV 163/1.65	593	350	712	420	125	6	76	3	1070	3 6 <sup>1</sup> / <sub>8</sub>	430	1 5	200	0 7 <sup>7</sup> / <sub>8</sub>	250	0 9 <sup>7</sup> / <sub>8</sub>	364	802
XRV 163/1.93	710	418	852	500	125	6	76	3	1116	3 8	430	1 5	200	0 7 <sup>7</sup> / <sub>8</sub>	250	0 9 <sup>7</sup> / <sub>8</sub>	388	855
XRV 204/1.10	812	478	974	573	150	6	100	4	1178	3 10 <sup>3</sup> / <sub>8</sub>	516	1 8 <sup>3</sup> / <sub>8</sub>	240	0 9 <sup>1</sup> / <sub>2</sub>	305	0 12	636	1400
XRV 204/1.45	1070	630	1284	756	150	6	100	4	1249	4 1 <sup>1</sup> / <sub>8</sub>	516	1 8 <sup>3</sup> / <sub>8</sub>	240	0 9 <sup>1</sup> / <sub>2</sub>	305	0 12	660	1454
XRV 204/1.65	1219	717	1463	860	150	6	100	4	1255	4 1 <sup>1</sup> / <sub>2</sub>	516	1 8 <sup>3</sup> / <sub>8</sub>	240	0 9 <sup>1</sup> / <sub>2</sub>	305	0 12	690	1520
XRV 204/1.93	1348	793	1618	952	150	6	100	4	1312	4 3 <sup>3</sup> / <sub>8</sub>	516	1 8 <sup>3</sup> / <sub>8</sub>	240	0 9 <sup>1</sup> / <sub>2</sub>	305	0 12	736	1621

The company operates a policy of continuous product development and reserves the right to alter the data provided without notice.